

Terminator™ ZT / FAK-4L Kit

Thermostat Connection In-Line Power Kit

For Use With TubeTrace™ Bundles

INSTALLATION PROCEDURES

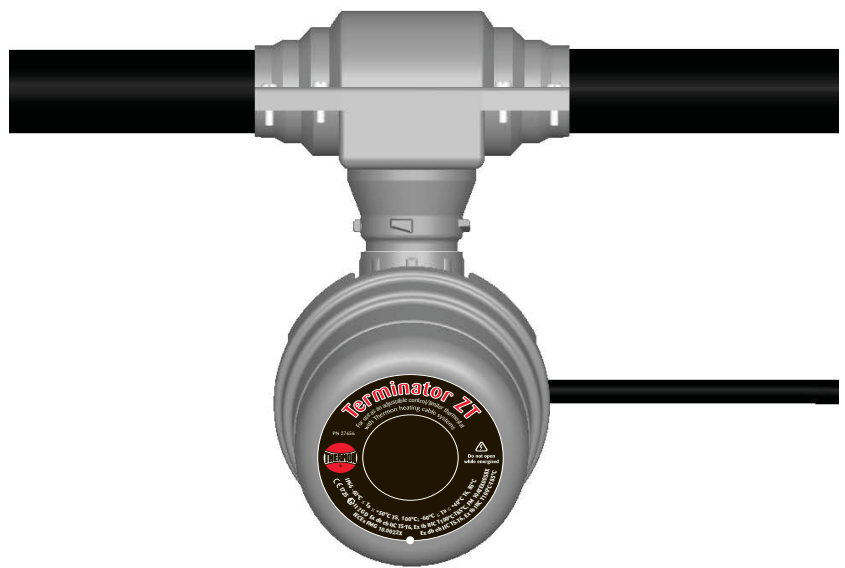

The Heat Tracing Specialists®

Terminator™ ZT / FAK-4L

The following installation procedures are suggested guidelines for the installation of the Terminator ZT / FAK-4L Thermostat Connection In-Line Power Kit.

Receiving, Storing and Handling . . .

1. Inspect materials for damage incurred during shipping.
2. Report damages to the carrier for settlement.
3. Identify parts against the packing list to ensure the proper type and quantity has been received.
4. Store in a dry location.

Terminator ZT / FAK-4L Kit Contents . . .



Item	Qty	Description										
1	1	Expediter Assembly: Support Cap with O-Ring, Threaded Grommet Compressor, Grommet, Support Base with O-Ring										
2	1	Junction Box Lid										
3	1	Junction Box Base with O-Ring and M25 Dust Cap										
4	1	Expediter Nut										
5	1	Thermostat w/ Terminal Blocks <small>(Refer to terminal specifications for maximum allowable wire size)</small>										
		<table border="0"> <tr> <td><u>Thermostat Type</u></td> <td><u>Control Range</u></td> </tr> <tr> <td>ZT-C-100</td> <td>0°C to +100°C</td> </tr> <tr> <td>ZT-C-200</td> <td>0°C to +200°C</td> </tr> <tr> <td>ZT-C-300</td> <td>0°C to +300°C</td> </tr> <tr> <td>ZT-C-500</td> <td>20°C to +500°C</td> </tr> </table>	<u>Thermostat Type</u>	<u>Control Range</u>	ZT-C-100	0°C to +100°C	ZT-C-200	0°C to +200°C	ZT-C-300	0°C to +300°C	ZT-C-500	20°C to +500°C
<u>Thermostat Type</u>	<u>Control Range</u>											
ZT-C-100	0°C to +100°C											
ZT-C-200	0°C to +200°C											
ZT-C-300	0°C to +300°C											
ZT-C-500	20°C to +500°C											
6	1	Junction Box Cord										
7	1	Bulkhead Entry Cover (Top)										
8	1	Bulkhead Entry Base (Bottom)										
9	1	Blind Plug										
10	12	Pan Head S.S. Screws, #10-32 x 19mm										
11	12	KEPT S.S. Nuts, #10-32										
12	3	M5 Screw										
13	3	M5 Lock Washer										
14	1	Heat Reflective Tape										
15	1	Glass Fiber Tape										
16	3	RTV Sealant Tube										
17	2	Small Bundle Adapter										

Dimensions . . .

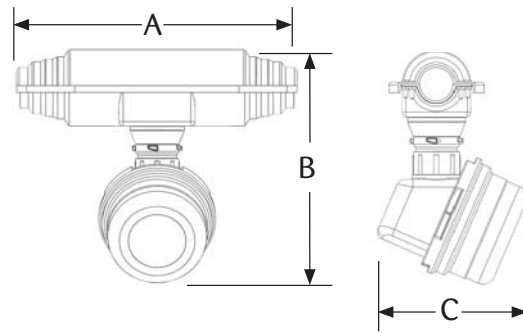

	A inch (mm)	B inch (mm)	C inch (mm)
Terminator ZT / FAK-4L	372 mm/14.6 in	308 mm/12.1 in	185 mm/7.3 in

Tools Required . . .



Order Separately . . .

PETK Power and End Termination Kits (per cable)

PETK-1	for RSX, VSX, BSX
PETK-2	for KSX, HTSX
PETK-3-ZT	for HPT, FP



The Heat Tracing Specialists®



INSTALLATION PROCEDURES

The Terminator ZT / FAK-4L Thermostat In-Line Power Kit is designed to provide accurate control with the ZT thermostat and make a waterproof seal over the end of TubeTrace and terminate Thermon electric heat trace in an approved Terminator junction box. Review Instructions prior to installation. Kit will make one connection.

Terminator ZT Certifications/Approvals . . .

IP66 -60°C ≤ Ta ≤ +50°C T5, 100°C; -60°C ≤ Ta ≤ +40°C T6, 85°C
Ordinary & Hazardous Locations

 FMG 10.0022X Ex db eb IIC T5-T6, Ex tb IIIC T100°C-T85°C

 1725  II 2 GD Ex db eb IIC T5-T6, Ex tb IIIC T100°C-T85°C FM10ATEX0058X

Installation Precautions . . .

- Keep ends of bundles, heat tracing and kit components dry before and during installation.
- To minimize the potential for arcing on electrical heat tracing caused by product damage or improper installation, use appropriate ground-fault circuit protection.
- Installation must comply with Thermon requirements and be installed in accordance with any applicable national and local codes.
- Component approvals and performance ratings are based on the use of Thermon specified parts only. User supplied power connection fittings must be listed or certified for intended use.
- De-energize all power sources before opening enclosure.
- Individuals installing these products are responsible for complying with all applicable safety and health guidelines. Proper personal protective equipment, or PPE, should be utilized during installation. Contact Thermon if you have any additional questions.

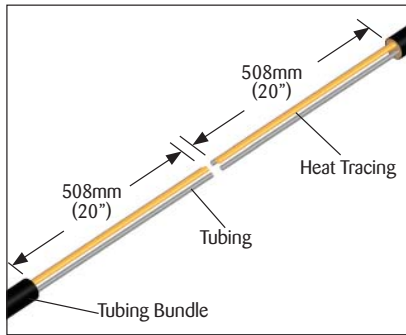

1. Remove outer jacket and insulation from tubing bundle approximately 508mm (20") from end of the tubing bundle.

 Do not cut or damage the heat trace or sampling tube.
CAUTION (Found on TubeTrace SE/ME bundles)

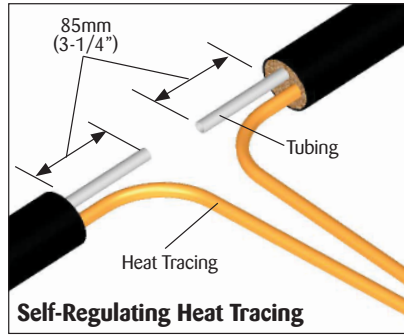

2. Trim tubing to within 85mm (3-1/4") of the end of the insulation. If self regulating heat trace proceed to step 3. For Zone-type heat trace continue with identification of bus connection on step 2a.

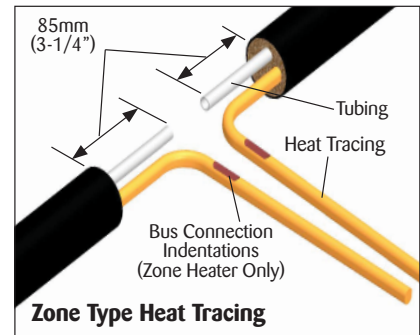

- 2a. Strip back bundle insulation 85mm (3 1/4") beyond bus connection indentation of each heat tracing. If bus connection indentation is less than 305mm (12")-381mm (15") from end of the heat tracing, proceed stripping the bundle insulation to the next indentation. Trim tubes so the bus connection indentation on each meet.

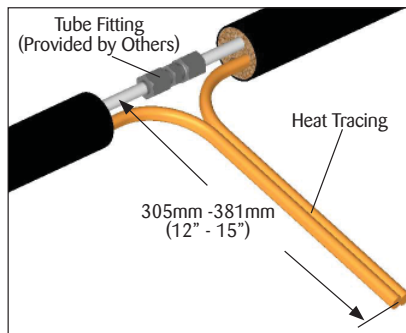

3. Make tube fitting connections with appropriate fitting (provided by others). Test fitting for leaks before proceeding. Mount tube fitting shifted from each other in case of multiple tubes.

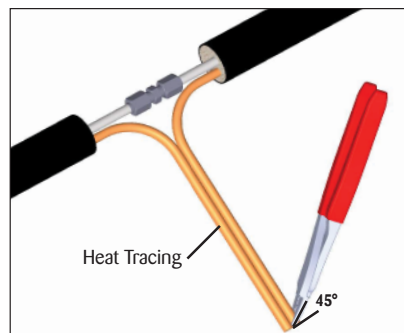

4. Cut the ends of the cable at an angle to aid in piercing grommet.

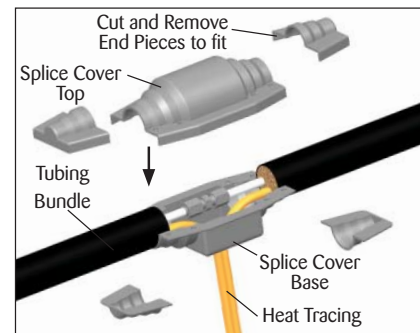

5. Cut splice cover ends to match outside diameter of tubing bundle. For bundle diameter less than 48mm remove only the closed in part.

Terminator™ ZT / FAK-4L

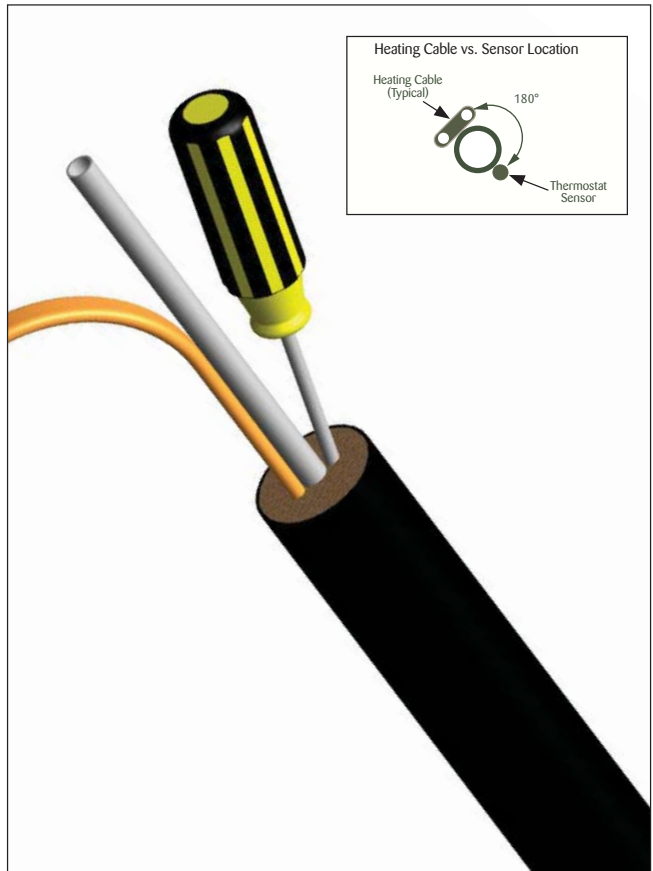
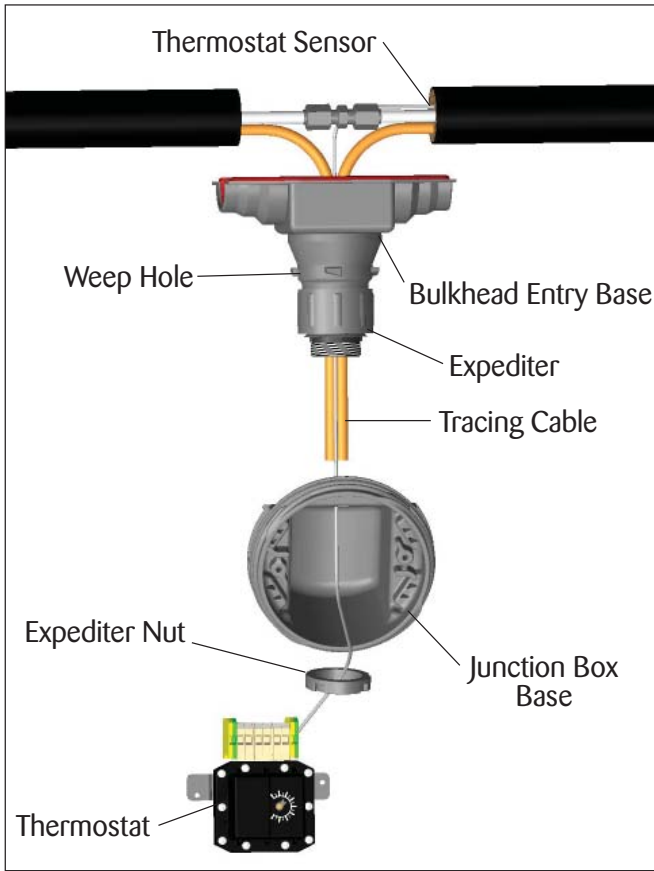

6. Route thermostat bulb through expediter nut and expediter opening in junction box base. If necessary, apply lubricant (user supplied) to the end of thermostat bulb. Slide through conical grommet hole. Insert the tracing cables through conical grommet holes and punch out weep hole.

7. Create a gap between the insulation and the tube with a screw driver for the sensor and place the sensor inside.

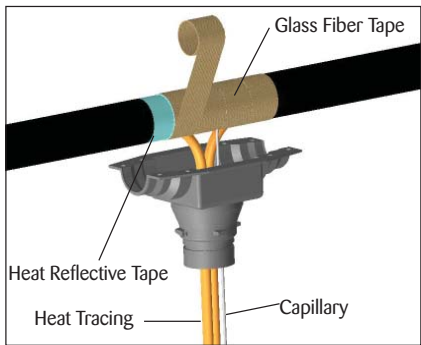

8. Wrap tube and heat trace with 1 pass of reflective tape (25% overlap), then wrap with 3 passes of glass fiber tape (50% overlap), or until fiber tape is equal to original bundle insulation thickness.

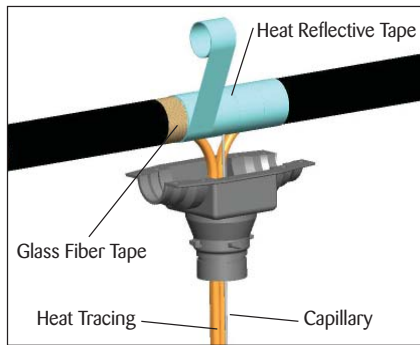

9. Complete with additional passes of heat reflective tape.

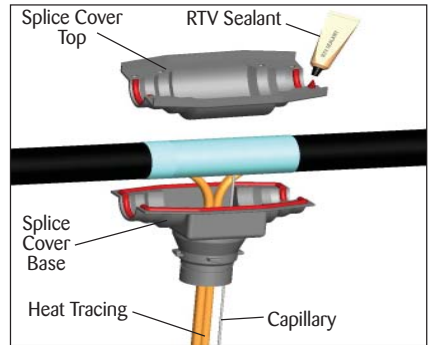

10. Form a gasket by applying RTV sealant to splice cover base and along radius of splice cover top as shown.

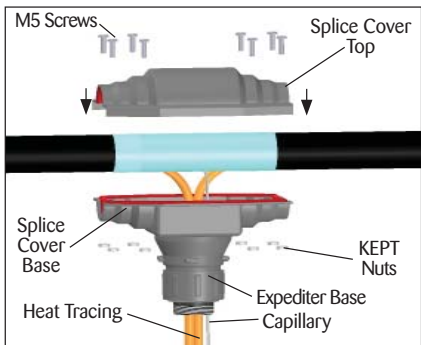

11. Assemble splice cover top, tubing bundle, and splice cover base together as shown, using 10-32 X 19mm pan head screws and KEPT nuts.

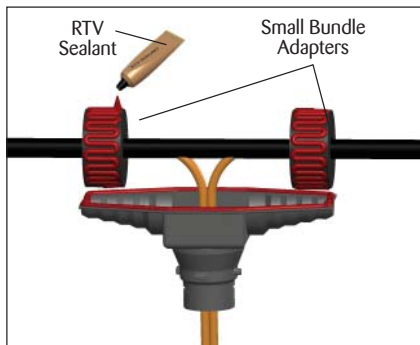

For Bundle Diameters Less Than 64 mm.
11a. Place small bundle adapters as shown. Apply RTV sealant to spacers liberally.

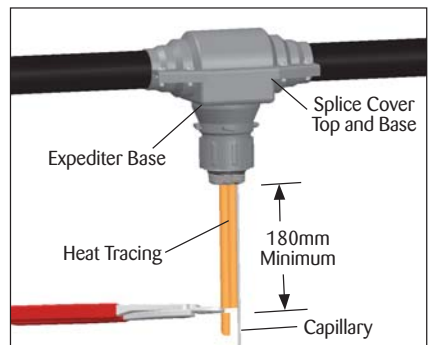

12. Trim heat tracing to 180mm minimum from expediter base.

INSTALLATION PROCEDURES

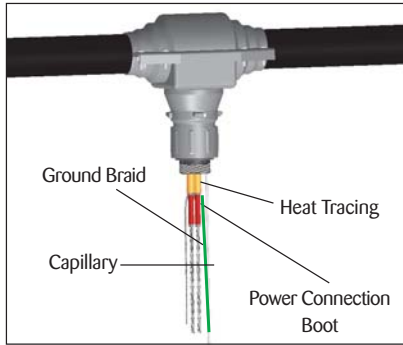

13. Terminate heat tracing with appropriate PETK termination kit. Refer to PETK installation instructions for details not addressed here. Tighten cap securely.

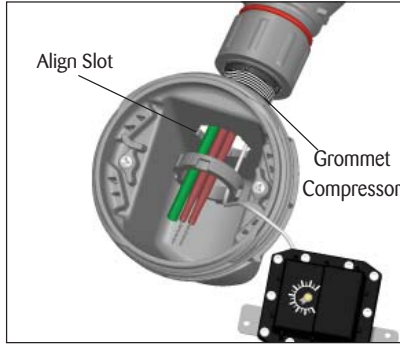

14. Mount junction box on expediter making sure to align slots to properly orient junction box base. Tighten nut with Terminator-LN-Tool.

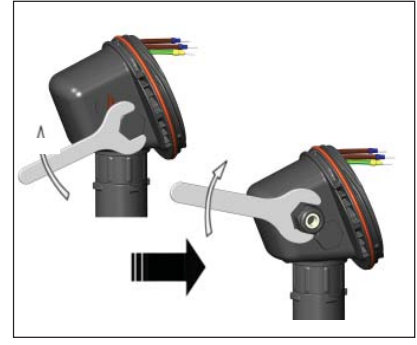

15. Remove M25 dust cap. Install M25 power gland (order separately) and M25 blind plug.



16. Install thermostat and complete system wiring. Terminal set screws shall be tightened to a torque value of 1.4 Nm (12.4 lb-in). See step 17 for wiring details. Set thermostat at desired setpoint.

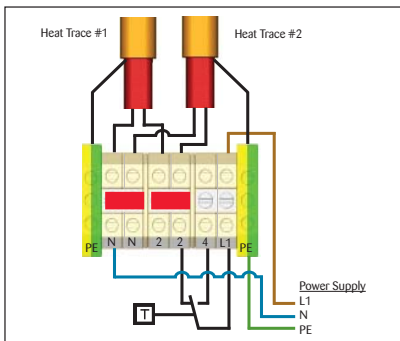

17. Wiring Details: Thermostat Connection (1 or 2 Heating Cables)

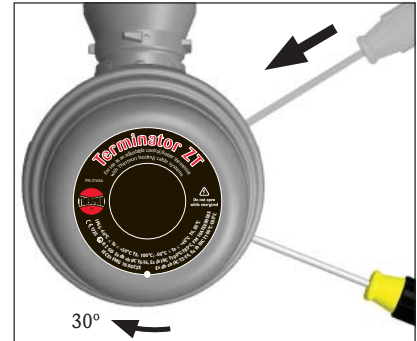

18. Install junction box lid and twist hand tight. Insert screwdriver into ratchet slot located on side of junction box base to tighten. Use screwdriver ratchet on junction box lid. Lid will rotate 30°. To remove lid, repeat steps but in opposite direction.

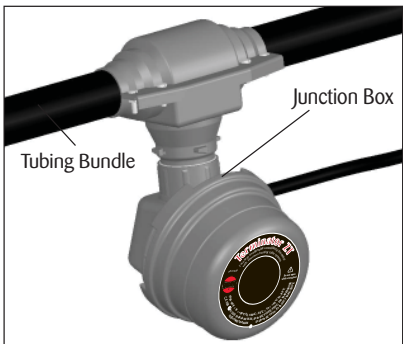

19. Completed Terminator ZT/FAK-4L power/thermostat assembly for TubeTrace Type SE/ME Bundle (Installation shown is to feed power in the middle of a TubeTrace bundle. Many installations will be near the end of a TubeTrace bundle.) Install bundle clamps (order separately) 300mm before and after In-line power kit.



THERMON . . . The Heat Tracing Specialists®
www.thermon.com

European Headquarters
Boezenweg 25 • PO Box 205
2640 AE Pijnacker • The Netherlands
Phone: +31 (0) 15-36 15 370

Corporate Headquarters
100 Thermon Dr. • PO Box 609
San Marcos, TX 78667-0609 • USA
Phone: +1 512-396-5801

For the Thermon office nearest you
visit us at . . .
www.thermon.com



Specifications and information are subject to change without notice. Form PN50090U-1013