



PRODUCT SPECIFICATIONS

HeetSheet®

VESSEL HEATING/COOLING SYSTEM

APPLICATION

HeetSheet tank heating units are constructed of 26-gage type 304 stainless steel, conforming to ASTM A240. The welded waffle style pattern provides multiple flow paths reducing risk of blockage possible with single-flow designs.

For temperatures up to 190°C, Thermon NH non-hardening heat transfer compound is factory applied to the surface of the HeetSheet unit that contacts the tank wall. This is to eliminate air gaps and optimize heat transfer.

HeetSheet units are available in multiple sizes and are pre-rolled to conform to the radius of the tank. Stainless steel tubing connections are provided for steam or other heating or cooling media. Customer supplied fittings are used to connect the inlet and outlet tubes to ThermoTube® pre-insulated supply and return tubing. ThermoTube is arranged separately.

RATINGS

Max. operating temperature	190°C
Minimum operating temperature.....	-196°C
Max. operating pressure.....	1,136 kPa g
Maximum field test pressure.....	1,700 kPa g
Heat transfer coefficient ¹	HeetSheet unit to tank wall 114-227 W/m ² -°C

ASME INSPECTION/CERTIFICATION

ASME does not require units of small internal volume and pressure rating to be certified. Specifically, the maximum stored energy in a HeetSheet unit falls well below the limits set by the Code for certification as defined by the following three volume and pressure points:

- 0.14 m³ and 1720 kPa
- 0.08 m³ and 2410 kPa
- 0.04 m³ and 4140 kPa

(No HeetSheet units approach these volumes. See Product Configuration table on reverse side for internal volume of standard HeetSheet units.)

HeetSheet units are designed and fabricated in accordance with the requirements of ASME Section VIII Div 1 Boiler and Pressure Vessel Code but are not inspected nor stamped.²

Notes

1. Information for design and performance is based upon the use of Thermon heat transfer compounds.
2. ASME inspection and stamping is available as an option for all heavy gage HeetSheet when specified on order.

THERMON The Heat Tracing Specialists®



European Headquarters: Boezemweg 25 • PO Box 205 • 2640 AE Pijnacker • The Netherlands • Phone: +31 (0) 15-36 15 37
 Corporate Headquarters: 100 Thermon Dr • PO Box 609 San Marcos, • TX 78667-0609 • Phone: 512-396-5801 • 1-800-820-4328
 For the Thermon office nearest you visit us at . . . www.thermon.com

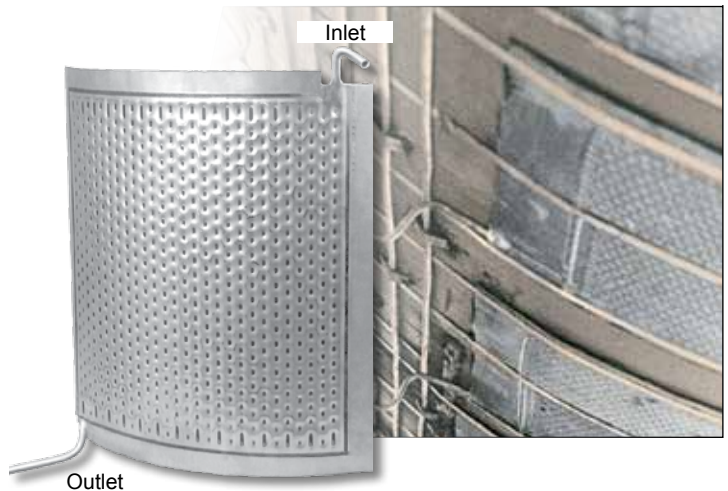

CONSTRUCTION

- 3/8" O.D. stainless tubing for inlet and outlet connections
- Type 304 stainless steel waffle pattern panel
- Factory-applied non-hardening heat transfer compound (see Typical Cross Section illustration)

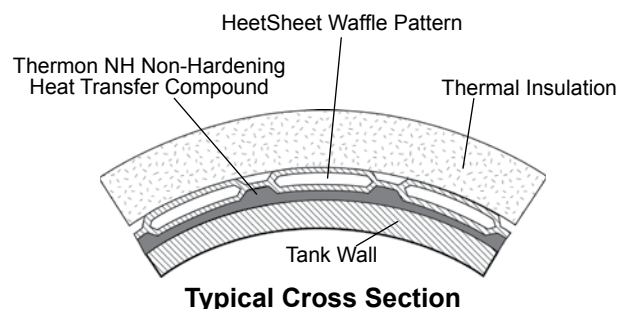

BENEFITS

- Each design is based on known and predictable heat transfer coefficients.
- Thermon heat transfer compounds provide high heat transfer rates.
- Requires only 1/2 to 1/3 the heating surface area of plate-type coils for like applications.
- Pre-rolled units assure quick installation.
- Used for both heating or cooling applications.
- No possibility for cross contamination of heating media and tank/vessel contents is possible.



PRODUCT SPECIFICATIONS

HeatSheet®

VESSEL HEATING/COOLING SYSTEM

TYPICAL TANK HEATING SYSTEM

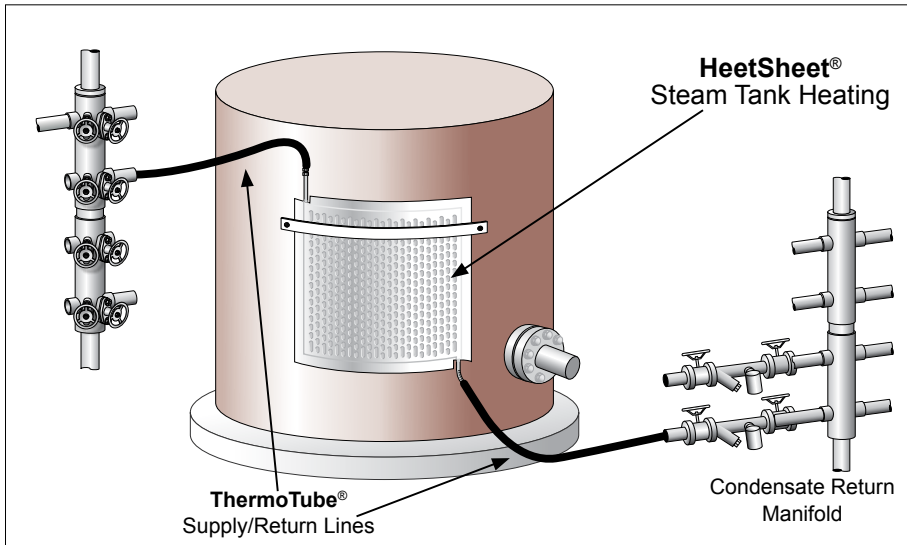

INLET & OUTLET CONFIGURATIONS

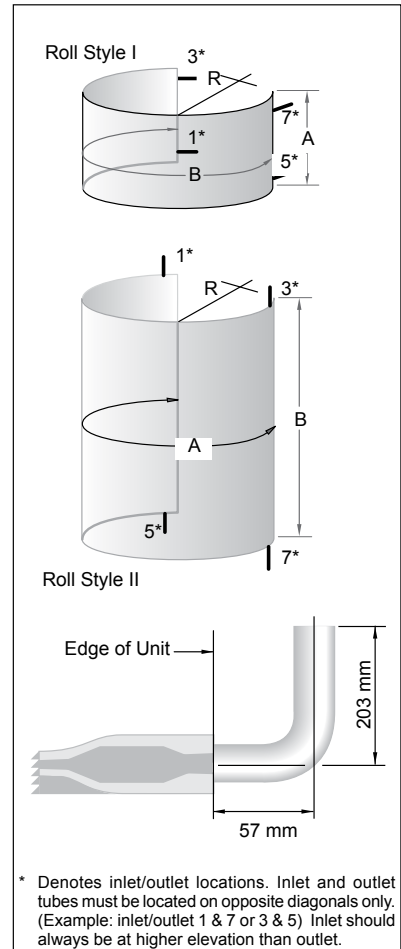

PRODUCT PROPERTIES²

Catalog Number ³	External Dimensions A x B mm	Nominal Heated Area m ²	Internal Volume cm ³	Approx. Weight Without Compound kgs	Approx. Weight With Compound kgs
HS-2	610 x 610	0.37	500	2.6	3.5
HS-3	610 x 915	0.55	750	3.9	5.2
HS-4	610 x 1220	0.74	1000	5.2	7.0
HS-6	610 x 1830	1.10	1500	7.8	10.5
HS-8	610 x 2440	1.49	2000	10.4	14.1

Notes

- Connections between the steam and condensate headers and the HeetSheet may be accomplished with ThermoTube pre-insulated tubing. ThermoTube is available in a variety of sizes to meet the requirements of the application. For information on ThermoTube pre-insulated tubing, refer to Form TSP0009.
- For sizes or product configurations other than those listed, contact Thermon.
- When ordering HeetSheet units without heat transfer compound, use the NC designation at the end of the catalog number. Example HS-2-NC.
- Pre-rolled radius of curvature is limited to a minimum of 102 mm for the 26 gage units.

BASIC ACCESSORIES



T3SSB stainless steel banding (.50" x .030") used to secure HeetSheet to tank.

C001 banding tool for applying tension to stainless steel banding.

1950A . . . crimping tool for T34PB-CR seals.

T34PB-CR crimp seals for fastening tensioned banding.



ThermoTube pre-insulated tubing used for steam supply and condensate return on steam heating circuits. (ThermoTube can also be utilized to transport other heating or cooling media.)



FAK-7 contains a roll of self-vulcanizing silicone rubber tape and RTV sealant to complete approximately six ThermoTube® terminations.



T-75 is a specialty heat transfer compound formulated for its exceptional bond strength and smooth spreading texture for surface heating applications. Can also be used with other manufacturers' plate-type coil units.