

## GF\_PROMER

Graphic setpoint programmer, 4 zones  
3.5" and 5.7" screens, TFT, Colour, Touch screen

### Main applications

- Furnaces for heat treatment of metals
- Ceramic furnace
- Laboratory furnaces for material tests
- Furnaces for tempering, aging, sintering
- Climate cells
- Test benches
- Incubators
- Autoclaves
- Dryers
- Greenhouses
- Chemical and pharmaceutical industry
- Firing furnaces
- Pasteurizers, sterilizers, food aging plants



### Main characteristics

- Color graphic display, TFT, 3.5" and 5.7" touch screen
- Complete "On Screen" programming, requires no configuration software
- Up to 4 control loops with setpoint profile
- Up to 300 steps in 100 programs
- Bar graph for PV, SP and OUT with selectable channels and zoom
- Up to 32 configurable I/Os for custom control strategies
- Configuration of logics and combined or timed automation sequences
- Active alarms management
- Recipes and historical data with USB support
- Functions: Self-tuning / Auto-tuning, Softstart, sensor diagnostics, solid-state actuators diagnostics
- Remote access for machine setup and diagnostics via Ethernet TCP
- Modbus TCP connection for data exchange with HMI

### PROFILE

GF\_PROMER performs, in a single device:

- Programmer functions for setpoints variable over time
- Controller function (up to 4 loops)
- Customizable logic/math functions with 100 steps
- Graphic recorder with trends
- Data storage with export on USB

### GRAPHIC INTERFACE

The operator interface, based on LCD TFT color touch screen (3.5" and 5.7") offers maximum simplicity of use. A series of graphic pages structured with different details provide complete monitoring of GF\_Promer operation. Icons facilitate access to the graphic pages, making navigation immediate and reliable.

No configuration software is needed to configure and use the programmer functions. The entire setup is provided from the graphics pages.

Integrated alarms management combined with an alarm notice on all pages provides an immediate check of work conditions of the controlled process.

Pages structured with Multi-language management simplify use of GF\_Promer by operators of different nationalities.

### PROGRAM CONFIGURATION

Up to 300 steps divided into 100 programs are provided for managing a controlled process.

Selection of their configuration and activation for execution on the machine is made easier by several interface pages. Repetition of programs and single steps, combined with copy/paste/add steps functions, simplifies and speeds configuration of a work program.

Programs can be stored in recipes and transferred to different machines via USB. Every program is identified by a configurable number and name, a time base (dd/hh, hh/mm, mm/ss), different stop and start strategies, and configurable group of PID parameters.

An intuitive graphic interface is provided for display of configured program profile in trend format.

Control functions for program states (Start/Stop/Reset/Skip) are provided as both graphic interface and as programmable I/O states.

A Realtime clock with weekly calendar is provided for timed activation of a program.

### CONTROL LOGICS

Up to 100 configurable steps with logic/math functions are provided for integrating control strategies based on both combined and timed automation logics and sequences in GF\_Promer.

The setup process (even on-board the machine) is made easier by complete configurability via the graphic interface without any external configuration software.

In combination with control strategies, you may match an (optional) series of I/O expansion modules for interface with an automatic machine/line control.

Control logics can be stored as a recipe and linked to various control programs.

### DATA STORAGE

Trend pages with variable selection and sampling time configuration (min/sec) offer paperless recording functions.

Storage of sampled Trend data on file also provides integrated DataLogging functions.

DataLogging values can be exported to .CSV file and transferred to PC on a USB drive.

Synchronization of Start/Stop recording with program Start/End is provided for

Batch processes. This provides safe and automatic storage of all data of a single Batch process in execution.

### REMOTE ACCESS

An Ethernet connection with Modbus TCP protocol provides an efficient tool to link GF\_Looper to HMI acquisition or supervision systems.

A complete map of variables with all general information on GF\_Looper operation and configuration is provided for data exchange with a Modbus TCP master.

For remote diagnostics or machine setup functions, there is a simple solution based on the graphic part of GF\_Looper that can be used with a Windows PC with Ethernet connection to the field instrument.

### CONTROLLER

Advanced control algorithms provide excellent management of process variables.

Various types of control are available: ON/OFF, P, PI, PID both only heat or cool and double-action heat+ cool.

In addition, the cool action can be set via indication of the cooling fluid used: air, oil, water. Calculation of the most appropriate process parameters is extremely rapid and efficient thanks to the use of sophisticated automatic tuning procedures. Advanced tuning lets you check the best PID parameters under all conditions.

### ALARMS

Two alarm setpoints (minimum and maximum) for each zone.

For each alarm, you can select:

- the control variable to assign to it

- setpoint value
- hysteresis value
- 5 properties (with latch, disable at switch-on, normal/symmetrical, absolute / deviation, direct/inverse).

You can set LBA, HB, SBR alarms: alarm presence is displayed with an icon and described on the alarms page.

### TECHNICAL DATA

#### OPERATOR INTERFACE

##### DISPLAY

Type: TFT Colour  
 Nr.colors: 262K  
 Diagonal: 3,5" (35CT) - 5,7" (57CT)  
 view area display: 70,08 x 52,56 mm (35CT)  
 117,2 x 88,4 mm (57CT)  
 Resolution: 320x240

Luminosity: 400 cd/mq (35CT)  
 500 cd/mq (57CT)

Contrast: 400:1 (35CT)  
 400:1 (57CT)

Backlighting: 8 white LEDs (35CT)  
 18 white LEDs (57CT)

Angle of view O/V: 75°/55°-75°(35CT)  
 75°/60°-75° (57CT)

Keyboard: 6 keys (35CT)  
 no keys (57CT)

Operations: > 3 million

#### TOUCH SCREEN

Type: Resistive, 4 wires  
 Life: >1,000,000 operations  
 Controller: integrated

#### PROCESSOR

Type: EP9307 Cirrus Logic

#### MEMORY

System: 128MB (SDRAM)  
 User: 512KB (SRAM)  
 Mass: 64MB (FLASH)

#### PERIPHERALS

Ethernet: Ethernet 10/100 Mbps Base-T - RJ45 Connector with led  
 Serial: RS485 optically isolated, baud rate 9,6...115 kBaud, RJ10 4p4c connector  
 USB Port: USB 2.0 HOST (500mA) type A 4 pin connector  
 BUS for I/O: Expansion for L-BUS4, 50 pin connector

#### POWER SUPPLY

24Vdc ± 25% (3 pin female screw-type connector)

Max consumption: 240mA 5W (35CT)  
 480mA 8,5W (57CT)

Max. consumption with I/O: 360mA 7W (35CT)  
 490mA 9W (57CT)

Protection: from polarity inversion (both) overcurrents on input circuit (57CT)

Battery: Lithium Manganese Dioxide 3V 65mA/h rechargeable (ML2032T6) life without power supply > 7500h  
 Expected life 7 years  
 Low-voltage signal

#### WEIGHT

(Kg): 0,4 (35CT) - 0,8 (57CT)  
 With 2 GilogikII modules  
 (Kg) 0,7 (35CT) - 1,1 (57CT)

## DESCRIPTION OF FRONT PANEL

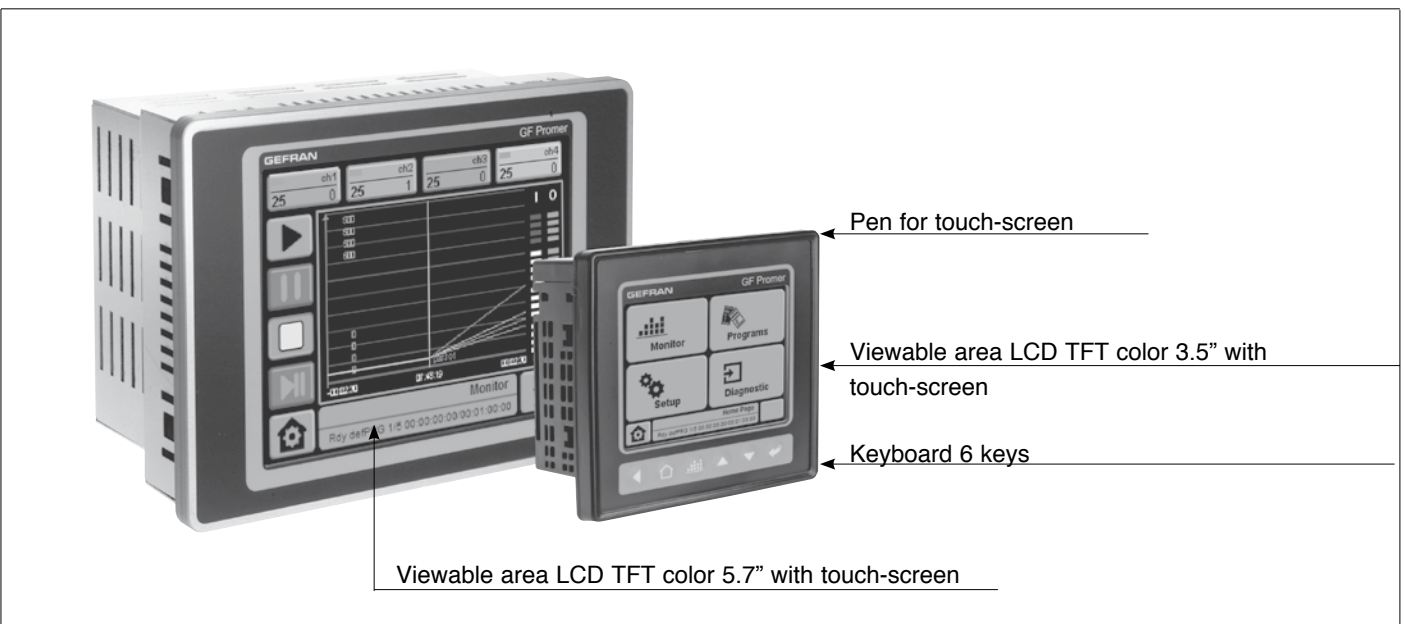

**GENERAL INFORMATION**

Front: 100x100x64mm (35CT)  
 169x120x76mm (57CT)  
 Protection IP65

with Gilogik II

modules: 100x100x171mm (35CT)  
 169x120x187 mm(57CT)

Template: 93x93mm (35CT)  
 162x115mm (57CT)

max panel thickness: 4mm (35CT)  
 3mm (57CT)





Certifications: CE, UL

**OPTIONAL UNITS / MODULES**

- Unit for distributed control
- GFX Controller single zone
- GFX4/ GFX4-IR zone modular power controller
- GFXTERMO4 Modular controller with 4 control zones (see the individual data sheets for characteristics of modular controllers)
- **R-EU16**: mixed module with 8 digital inputs and 8 digital outputs. The 24V PNP inputs have a programmable software filter. The module is organized in 8 inputs + common GND and 2 groups of 4 outputs. The PNP outputs are provided for inductive loads and protected against short circuit, overload and overheat.

*See the individual data sheets for characteristics of modules.*

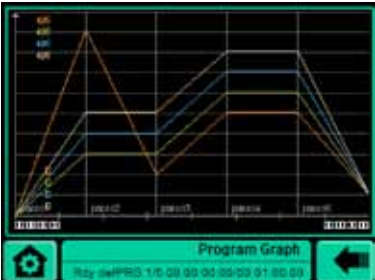
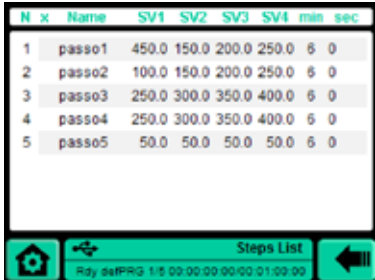
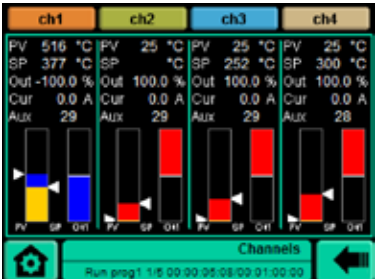
**GRAPHICS PAGES**

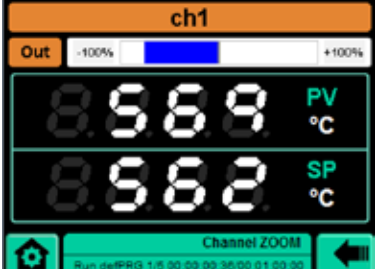
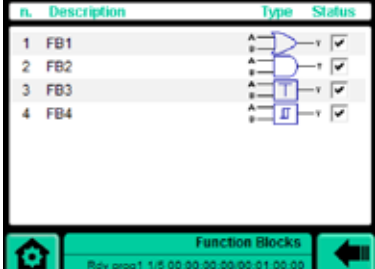
Setup	→		←		Programs List
Program Graph	→		←		Steps List
Channels	→		←		Monitor
Channels Zoom	→		←		Function Blocks

## USER CONNECTIONS

The user resource connections indicated in Table 4 are made at the bottom with standard connectors and Gefran custom connectors.

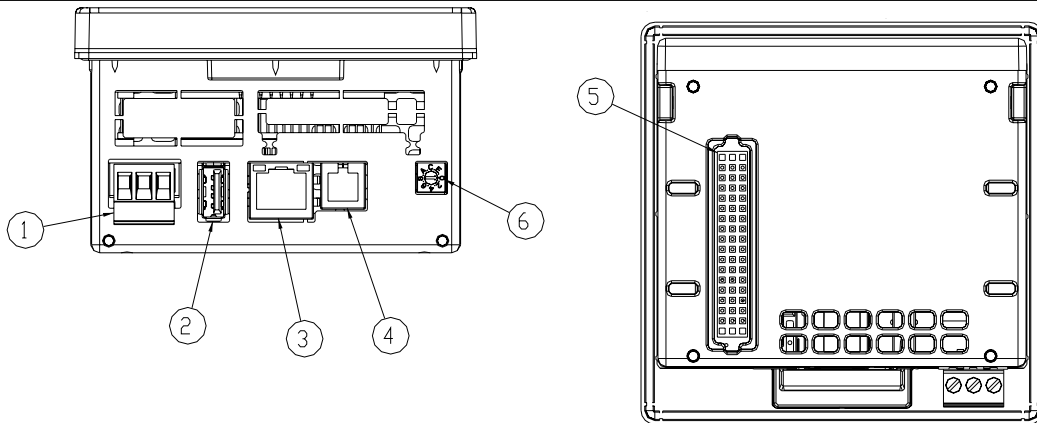

GF\_PROMER 35

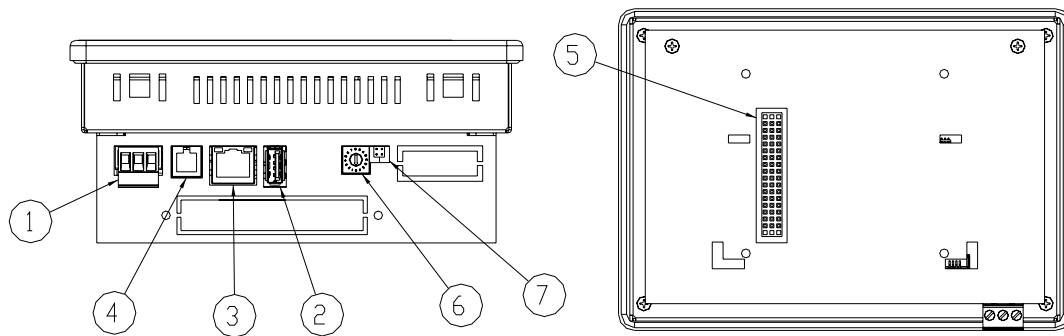

Name	Description
1	Supply
2	USB
3	Ethernet 10/100
4	Seriale RS485 Serial commun.
5	BUS-G
6	Rotary-switch
7	Enable batery

Description of connectors

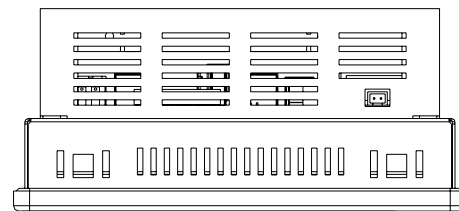

GF\_PROMER 57

### Connection with optional units / modules

For all information on connecting:

- Backplane L-BUS4
- GFX
- GFX4 / GFX4-IR
- GFXTERMO4
- R-EU16

see the data sheets and manuals.

Connection with GFXTERMO4 unit

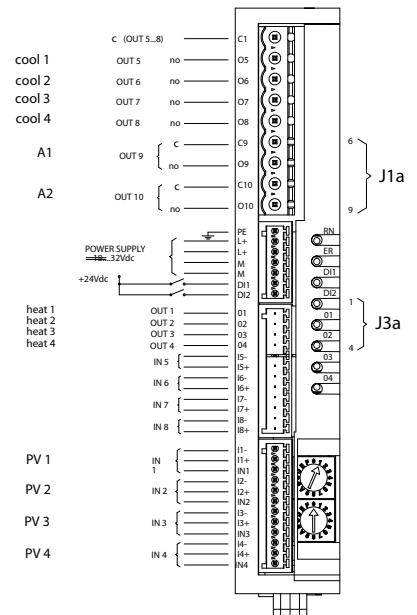
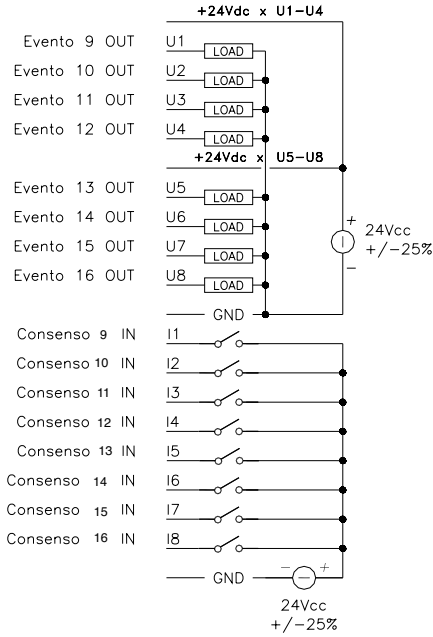
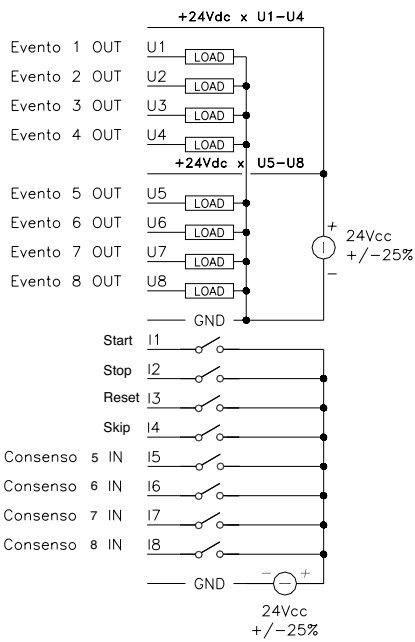
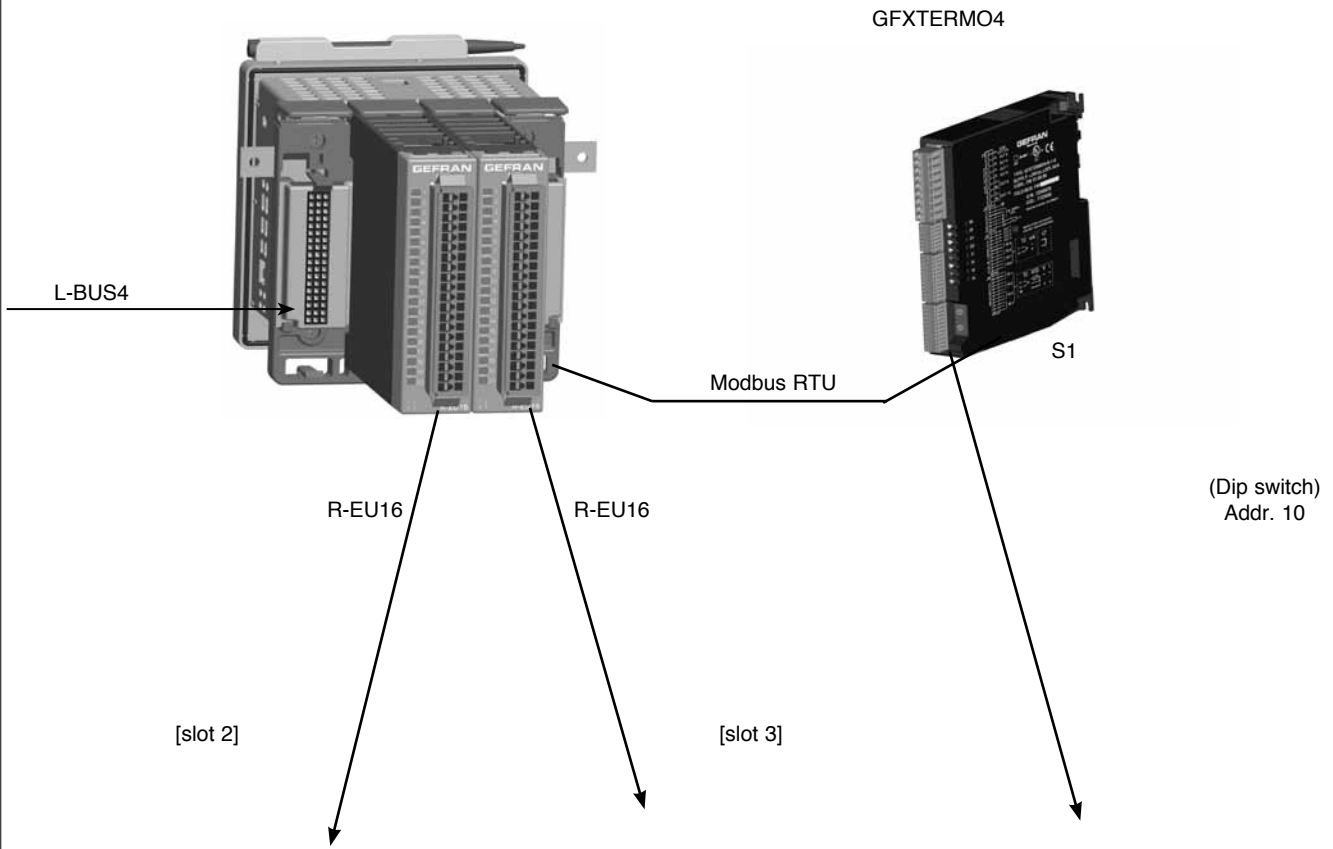

A1 = OR alarm 1 or 3 of zones 1-4  
A2 = OR alarm of zones 1-4

**OVERALL DIMENSIONS AND TEMPLATE**

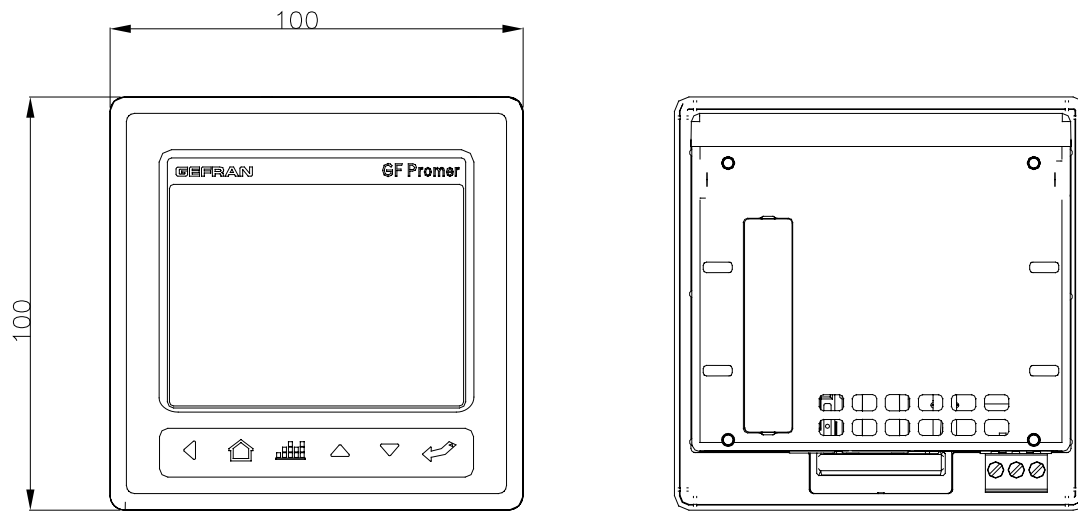
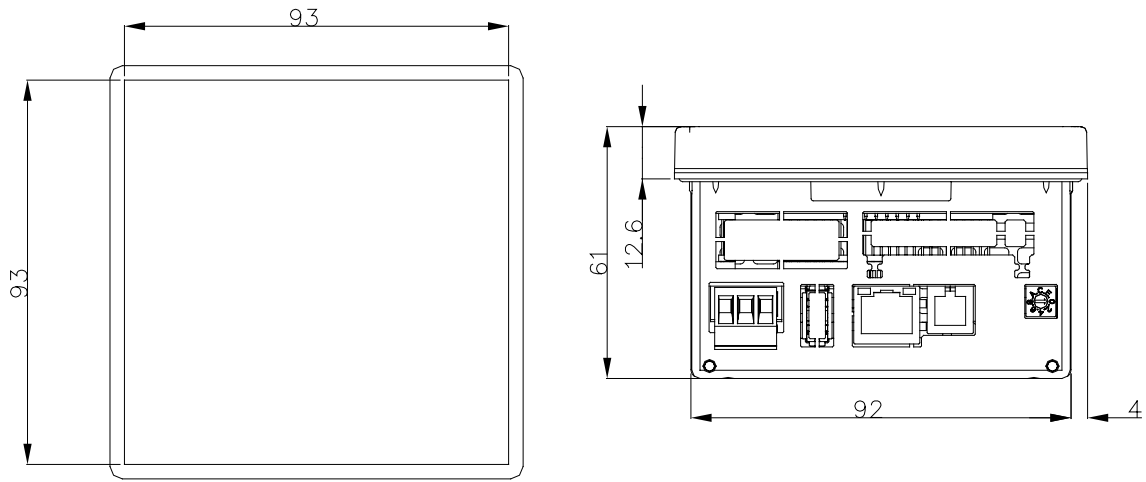

Physical dimensions and for drilling template - 35CT -

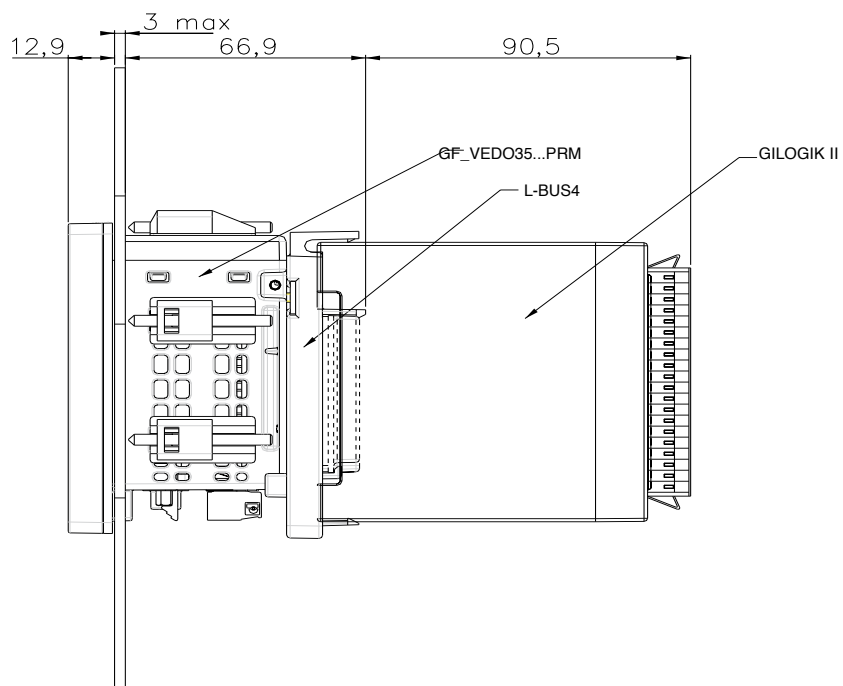

Overall dimensions - 35CT -

**OVERALL DIMENSIONS AND TEMPLATE**

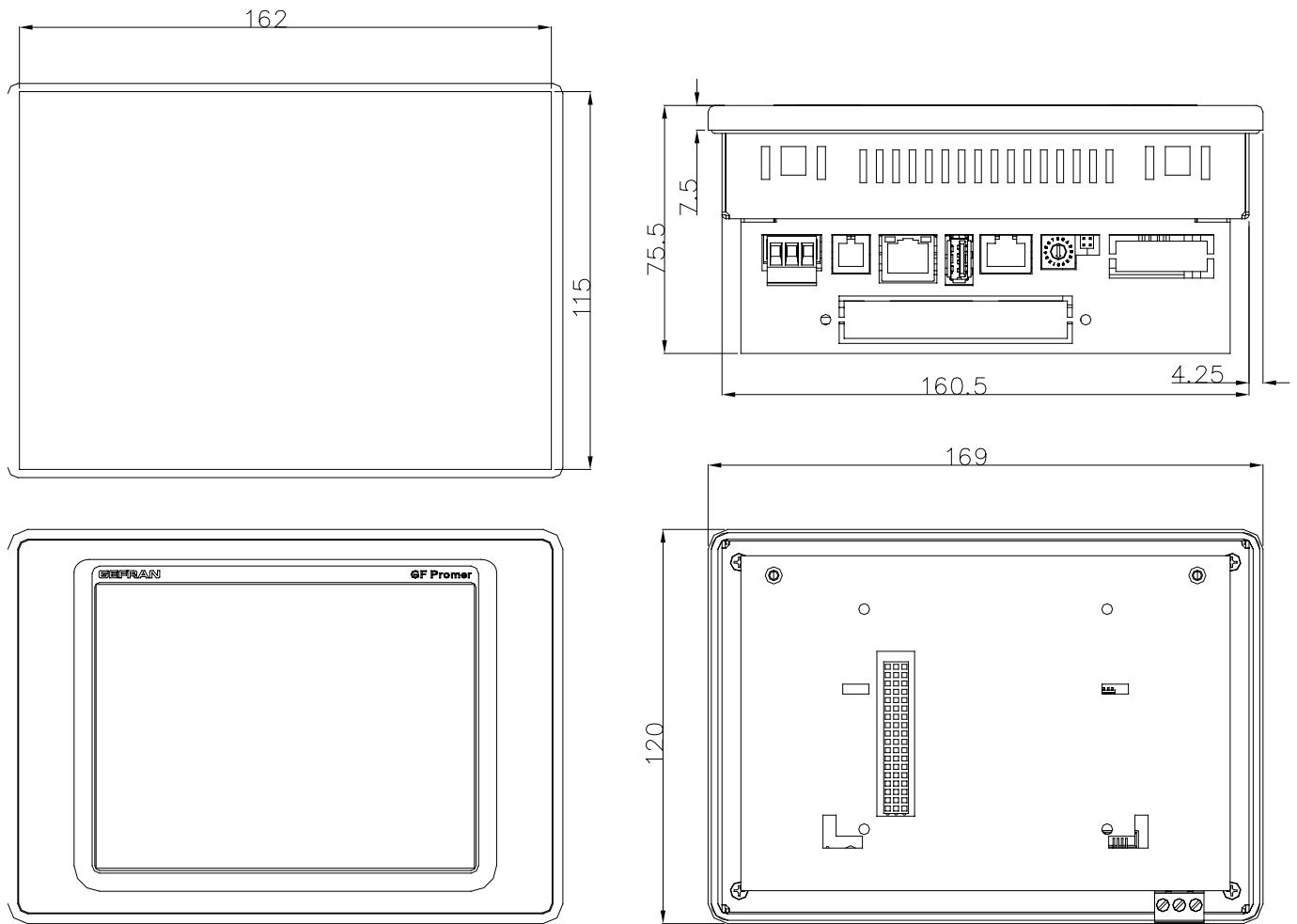

Physical dimensions and for drilling template - 57CT -

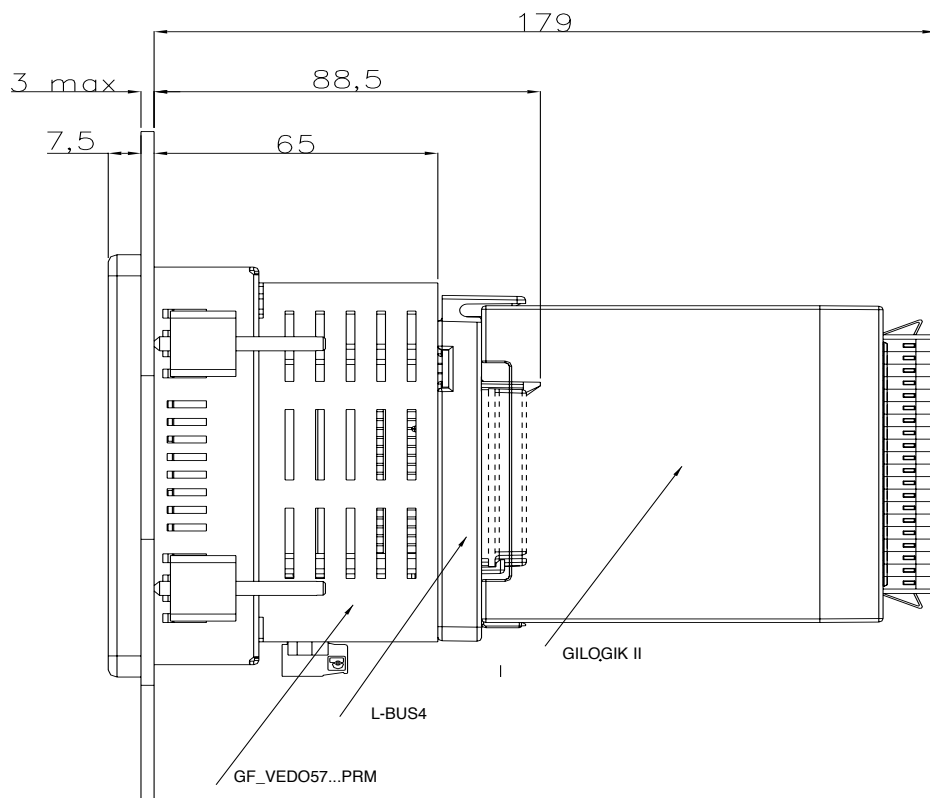

Overall dimensions - 57CT -

## ORDERING CODE

GF\_PROMER

	LX0	0		0	0	U	
--	-----	---	--	---	---	---	--

DISPLAY	
3,5"color + touch screen	35CT
5,7"color + touch screen	57CT

CONTROL TYPE	
<b>Distributed</b> (unit connected via RS485 serial) With GFX/GFX4 - GFX4-IR / GFXTERMO4	0

ENABLE INPUTS / AUXILIARY EVENT OUTPUTS	
(GilogikII module(s) included in supply, with L-BUS4 backplane, SLOT 2 and 3)	
none	0
8DI+8DO (1 module R-EU16 in slot 2)	1
16DI+16DO (2 modules R-EU16 in slot 2-3)	2

Fieldbus	
None	0

Additional SW options	
Nessuna	0

USB port	
USB	U

LEXAN	
Gefran	G
Neutre	N

Please contact GEFRAN for information regarding availability of codes

GEFRAN spa reserves the right to make aesthetic and/or functional changes at any time and without notice.

<b>UL</b>	Conformity C/UL/US File no. 198546
<b>CE</b>	The instrument conforms to the European Directives 2004/108/CE and 2006/95/CE with reference to the generic standards: <b>EN 61131-2</b> (product) - <b>EN 61010-1</b> (safety)

**GEFRAN**

**GEFRAN spa**  
 via Sebina, 74  
 25050 Provaglio d'Iseo (BS)  
 Tel. +39 030 9888.1 - fax +39 030 9839063  
 Internet: <http://www.gefran.com>

DTS\_GF\_PROMER\_02-2012\_ENG